

외형치수도-SSJ (표준형)

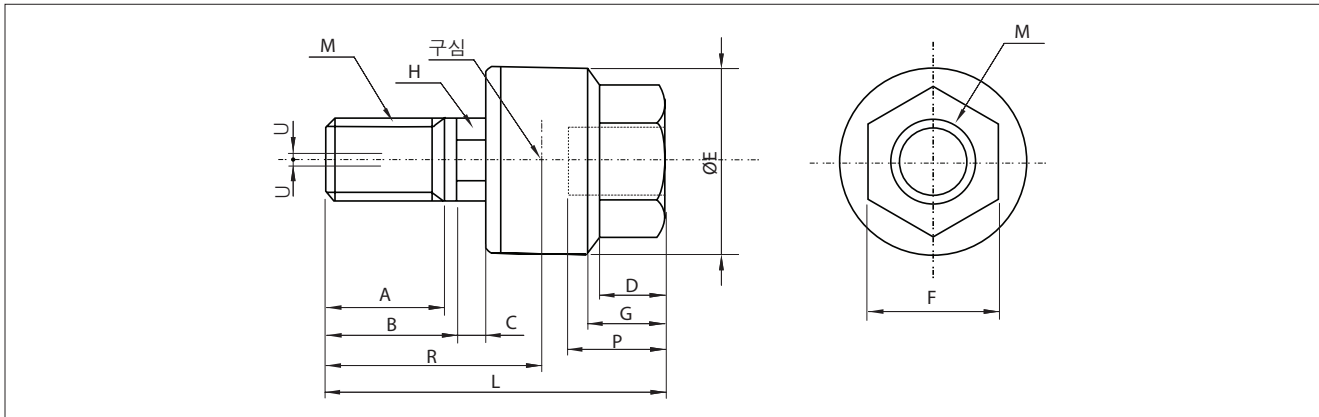

단위:mm

공압실린더 튜브내경	모델	A	B	C	D	E	F	G	H	L	M	구심 R	최대 나사 체결깊이 P	허용 편심량 U	최대 사용 인장압축력 (N)	중량 (kg)
Ø10	SSJ10-04-070	9	10	1.5	4	12	7	5	4	26	M4X0.7	17	5.5	0.5	54	0.01
Ø15	SSJ15-05-080	12.5	14	2	5	16	10	7	6	34.5	M5X0.8	23	7	0.5	123	0.02
	SSJ15-06-100	12.5	14	2	5	16	10	7	6	34.5	M6X1.0	23	7	0.5	123	0.02
Ø20	SSJ20-08-125	15.5	16.5	5	7	21	13	8	7	44	M8X1.25	30.5	8	0.5	1100	0.05
Ø25, Ø30	SSJ30-10-125	17.5	18.5	5	8	24	17	9	8	49	M10X1.25	34	9	0.5	2500	0.07
Ø40	SSJ40-14-150	20	22	5	11	31	22	12	11	62	M14X1.5	38	13	0.75	6000	0.16
Ø50, Ø63	SSJ63-18-150	25	27	6	13	40	27	14	14	76	M18X1.5	47.5	15	1	11000	0.31
Ø80	SSJ80-22-150	27	29	8	16	50	32	17	19	89	M22X1.5	56.5	18	1.25	18000	0.58
Ø100	SSJ100-26-150	35	37	8.5	20	59.5	41	24	24	110	M26X1.5	68	24	2	28000	1.08
Ø125, Ø140	SSJ140-30-150	41.5	44.5	14	22	79	46	30	27	153	M30X1.5	94.5	38	2.5	54000	2.7
Ø150, Ø160	SSJ160-36-150	52	54.5	16	24	96	55	36	32	179	M36X1.5	112	42	3	71000	4.7

외형치수도-SFJ (플랜지형)

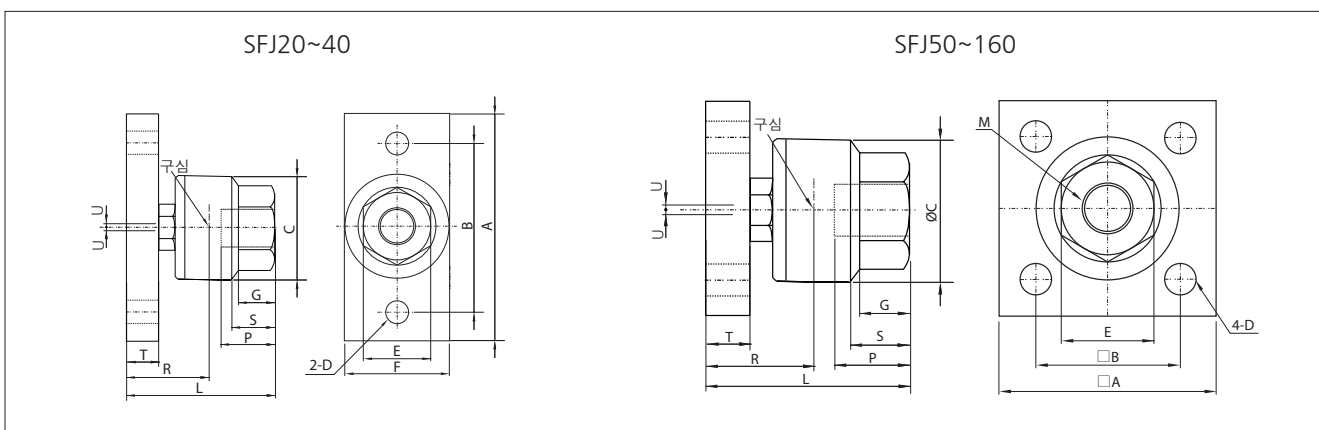

단위:mm

공압실린더 튜브내경	모델	A	B	C	D	E	F	G	L	M	S	T	구심 R	최대 나사 체결깊이 P	허용 편심량 U	최대 사용 인장압축력 (N)	중량 (kg)
Ø20	SFJ20-08-125	48	36	21	6.6	13	19	7	32.5	M8X1.25	8	6	19	8	0.5	1100	0.08
Ø25, Ø30	SFJ30-10-125	52	40	24	6.6	17	25	8	36	M10X1.25	9	6	20.5	9	0.5	2500	0.12
Ø40	SFJ40-14-150	70	52	31	9	22	32	11	49	M14X1.5	12	9	27	13	0.75	4400	0.28
Ø50, Ø63	SFJ63-18-150	65	45	41	9	27	-	13.5	61.5	M18X1.5	14	12	34.5	15	1	11000	0.63
Ø80	SFJ80-22-150	75	55	50	11	32	-	16	76.5	M22X1.5	17	16	43.5	18	1.25	18000	1.15
Ø100	SFJ100-26-150	90	65	59.5	11	41	-	20	94	M26X1.5	24	19	52	24	2	28000	2.07
Ø125, Ø140	SFJ140-30-150	131	82	79	18	46	-	22	131	M30X1.5	30	24	73.5	38	2.5	36000	5.2
Ø150, Ø160	SFJ160-36-150	152	100	96	22	55	-	24	152	M36X1.5	36	29	86	42	3	55000	9